

Conical open head drums 15 - 216.5 liters



07.01 E

Advantages

- UN homologation for solid and fluid dangerous goods
- Nestable, stable construction when empty or filled
- Space saving, cost reducing
- Full automatic closure with the Jet-Ring closing system available
- Compliance with 94/62 EC
- Coatings also can comply with EC 1895/2005, AP 96 (5) EC, BAG, BGA, FDA, EU 90.128/EEC
- Fully drainable

Construction

- Body overlapped welded, bottom seamed with injected sealing compound
- As option with handles, PE inliner and cover
- 3 different hoops available

Materials

- Mild steel St 12.03, galvanized or stainless steel
- Lid with PUR, PUR-DF or rubber sealing
- Closing ring galvanized or stainless steel (Pharma - like or Jet-Ring system with tamper-proof seal)

Surface treatment

- Galvanized, lacquered or powder coated
- Exactly suitable for your products
- With or without silk screening on body and top

Remarks

- Rational filling and optimal emptying
- Material recyclable without any problems
- Extremely stable construction with 180 mm hoop, upon request

Quality management

- ISO 9001:2000



Müller Ltd Packaging
Tramstrasse 20
CH-4142 Münchenstein 1

A Company of the Müller-Group
www.mueller-group.com

Phone: ++41(0)61/4161200
Fax: ++41(0)61/4161222
Internet: www.muellerdrums.com
E-mail: info@muellerdrums.com

Technical information



07.01 E

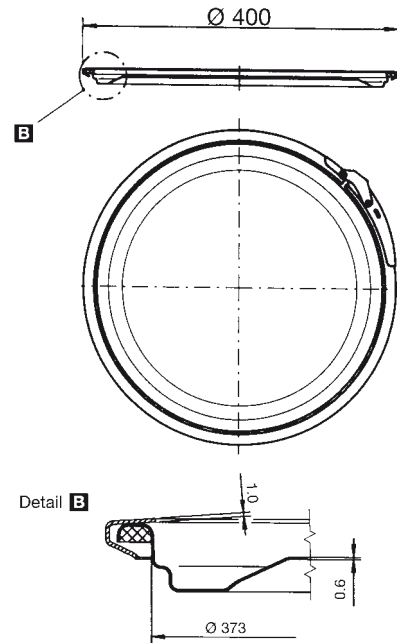
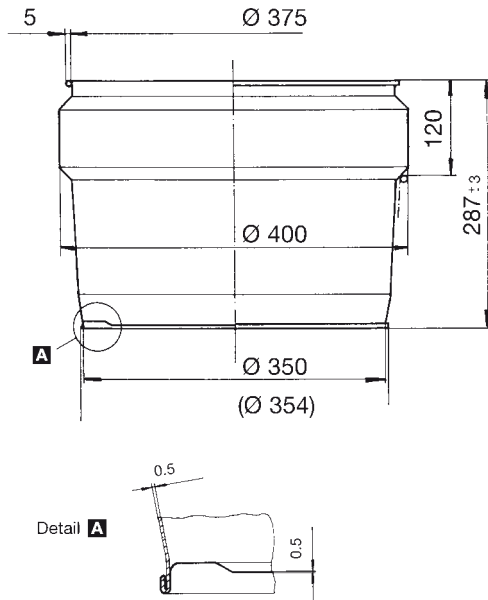

This example shows a conical 28 liter open head drum

Capacity Ltr.	Diameter mm	Thickness mm Bottom/Body/Top	UN Marking
20	300 / 285	0,4 / 0,4 / 0,4	UN 1A2/X25/S/./CH2062
50/60	375 / 350	0,4 / 0,4 / 0,4	UN 1A2/X50/S/./CH3098
60	375 / 350	0,4 / 0,5 / 0,4	UN 1A2/Y60/S/./CH2835
65	375 / 350	0,5 / 0,5 / 0,6	UN 1A2/X75/S/./CH2059
65	375 / 350	0,75 / 0,75 / 1,0	UN 1A2/X70/S/./CH2382
65	375 / 350	0,5 / 0,5 / 1,0	UN 1A2/X70/S/./CH2552
85	375 / 350	0,5 / 0,6 / 0,6	UN 1A2/X85/S/./CH2544
102	450 / 405	0,6 / 0,6 / 0,6	UN 1A2/X110/S/./CH3072
102	450 / 405	0,6 / 0,6 / 0,6	UN 1A2/X100/S/./CH2061
102	450 / 405	0,6 / 0,75 / 0,6	UN 1A2/X100/S/./CH3063
124	500 / 465	0,75 / 1,0 / 0,75	UN 1A2/X125/S/./CH2624
124/140	500	0,6 / 0,6 / 0,6	UN 1A2/X150/S/./CH/EGI-3841
130	500 / 465	0,75 / 0,75 / 0,6	UN1A2/X50/S/./CH2060
130	500 / 465	0,6 / 0,6 / 0,6	UN 1A2/X130/S/./CH2143
216,5	571,5 / 535	1,0 / 0,75 / 1,0	UN 1A2/X200/S/./CH2218 DOT 37A 275 STC 22/20 - 55 - M
216,5	571,5 / 535	1,0 / 0,75 / 1,0	UN 1A2/X/200/S/./CH2775 DOT 37A 275 STC 22/20 - 55 - M

Palletizing example

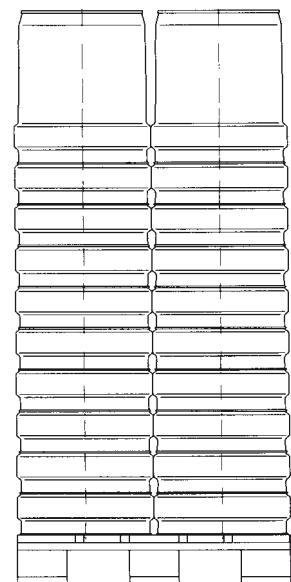

Other sizes and design upon request

Also available for fluid products

For more information please contact us and ask for detailed technical documentation

Müller Ltd Packaging
Tramstrasse 20
CH-4142 Münchenstein 1

A Company of the Müller-Group
www.mueller-group.com

Phone: ++41(0)61/4161200
Fax: ++41(0)61/4161222
Internet: www.muellerdrums.com
E-mail: info@muellerdrums.com