

Cylindrical open head drums 15 - 175 liters



07.02 E

Advantages

- UN homologation for dangerous goods
- Pilable, stable construction when empty or filled
- Full automatic closure with the Jet-Ring closing system as option
- Compliance with 94/62 EC
- Coatings also can comply with EC 1895/2005, AP 96 (5) EC, BAG, BGA, FDA, EU 90.128/EEC
- Fully drainable

Construction

- Body overlapped welded, bottom seamed with injected sealing compound
- As option with handles, PE inliner and PET cover, thus reusable body
- Different hoops / corrugations available

Materials

- Mild steel St 12.03, galvanized or stainless steel
- Lid with PUR, PUR-DF or rubber sealing
- Closing ring galvanized or stainless steel (Pharma-like or Jet Ring system with tamper evident mounted)

Surface treatment

- Galvanized, lacquered or powder coated
- Exactly suitable for your products
- With or without silk screening on body and lid

Remarks

- Rational filling and optimal emptying
- Materials recyclable without any problems

Quality management

- ISO 9001:2000



Müller Ltd Packaging
Tramstrasse 20
CH-4142 Münchenstein 1

A Company of the Müller-Group
www.mueller-group.com

Phone: ++41(0)61/4161200
Fax: ++41(0)61/4161222
Internet: www.muellerdrums.com
E-mail: info@muellerdrums.com

Technical information



07.02 E

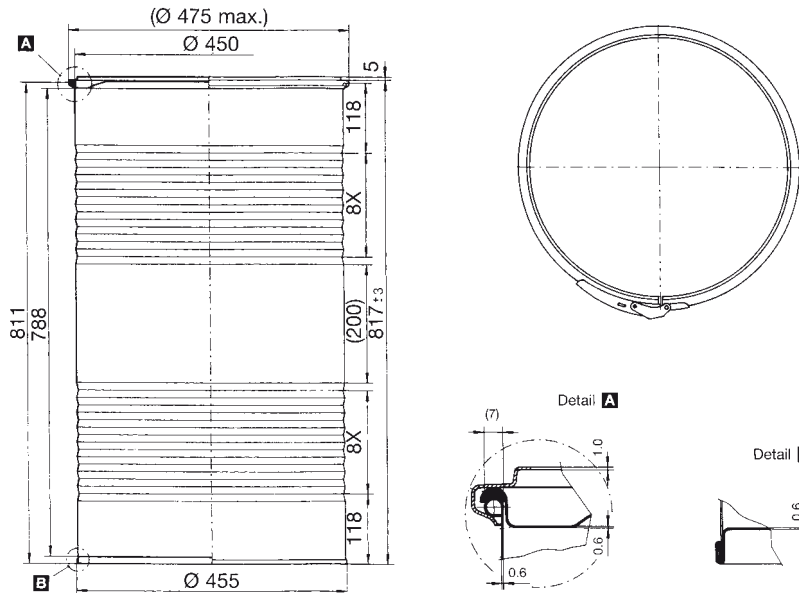

This example shows a Cylindrical 120 liter open head drum

Capacity Ltr.	Diameter mm	Thickness mm Bottom/Body/Top	UN Marking	Remarks
20	300 / 285	0,4 / 0,5 / 0,4	UN 1A2/X25/S/./CH2251	
24	280	0,4 / 0,4 / 0,4	UN 1A2/X30/S/./CH/EGI-3509	
25	285	0,6 / 0,75 / 0,6	UN 1A2/X35/S/./CH2202 Y1.6/120	
26	285	0,6 / 0,6 / 0,6	UN 1A2/Y120/./CH2849 X35/S	
40	355	0,5 / 0,5 / 0,5	UN 1A2/Y105/S/./CH/EGI-3547	SPR 30 x 1,5
50	360	0,5 / 0,5 / 0,5	UN 1A2/Y30/S/./CH2144	
54	375	0,5 / 0,5 / 0,5	UN 1A2/X54/S/./CH2836 Y54/S	By use of inliner Direct filling Y54/S
60	355	0,5 / 0,5 / 0,5	UN 1A2/X79/S/./CH/EGI-3629	SPR 30 x 1,5
60 / 75	355 / 345	0,5 / 0,5 / 0,6	UN 1A2/X79/S/./CH2472	Deep drawn lid SPR 27 x 1,0 mm
74	375	0,6 / 0,6 / 0,6	UN 1A2/X75/S/./CH2625	
80	400	0,6 / 0,5 / 0,6	UN 1A2/X125/S/./CH/EGI-3429	SPR 30 x 1,5
100	400	0,5 / 0,6 / 0,5	UN 1A2/X100/S/./CH/2123	2 Rolling hoops
113	560	0,5 / 0,5 / 0,5	UN 1A2/Y90/S/./CH2553	
107 / 120	450	0,6 / 0,6 / 0,6	UN 1A2/X100/S/./CH2145	
132	500	0,5 / 0,5 / 0,6	UN 1A2/X130/S/./CH/EGI-3322	
132 / 138	500	0,6 / 0,6 / 0,6	UN 1A2/X130/S/./CH2388	
150	500	0,75 / 0,75 / 0,75	UN 1A2/X125/S/./CH2147	
150	500	0,75 / 0,75 / 1,0	UN 1A2/X150/S/./CH/EGI-3214	lid middle Ø 285 Hoops
175	575	0,75 / 0,75 / 0,75	UN 1A2/Y120/S/./CH2837	

Other sizes and design upon request

For more information please contact us and ask for detailed technical documentation

Müller Ltd Packaging
Tramstrasse 20
CH-4142 Münchenstein 1

Phone: ++41(0)61/4161200
Fax: ++41(0)61/4161222
Internet: www.muellerdrums.com
E-mail: info@muellerdrums.com

A Company of the Müller-Group
www.mueller-group.com