

# Cylindrical open head drums 215 liters with/without PE-Inliner and PET/PP cover



**07.06 E**

## Advantages

- UN homologation for solid and fluid dangerous goods
- Compliance with 94/62 EC
- Coatings also can comply with EC 1895/2005, AP 96 (5) EC, BAG, BGA, FDA, EU 90.128/EEC
- Full automatic closure ring with Jet-Ring system
- Fully drainable
- Materials recyclable without any problems when empty
- It is possible to reuse the drum by changing liner and cover

## Construction

- Body overlapped welded, bottom seamed to body with injected sealing compound
- Liner version enables the drum to empty, leaving less residues than a standard drum

- Closing ring galvanized or stainless steel, tamper evident mount in the outer lever handle, plastic lid with PUR sealing
- 2" und 3/4" bungs possible in the metal lid as well as 2 x 2" in plastic lid
- Different hoops and corrugations possible
- Absolute shrink free mounting of the inliner upon demand

## Materials

- Mild steel St 12.03, galvanized or stainless steel
- PE-Inliner blow moulded, cover stretched with PU sealing compound flowed in

## Surface treatment

- Galvanized or lacquered
- Optional lacquer lining inside/outside for aggressive chemicals
- Exactly suitable for your products
- On line silk screening on body and top available

## Remarks

- Designed for optimum strength and volume
- Rational filling and handling
- Ideal for emptying with piston pump

## Quality management

- ISO 9001:2000



Müller Ltd Packaging  
Tramstrasse 20  
CH-4142 Münchenstein 1

A Company of the Müller-Group  
[www.mueller-group.com](http://www.mueller-group.com)

Phone: ++41(0)61/4161200  
Fax: ++41(0)61/4161222  
Internet: [www.muellerdrums.com](http://www.muellerdrums.com)  
E-mail: [info@muellerdrums.com](mailto:info@muellerdrums.com)

# Technical information



**07.06 E**

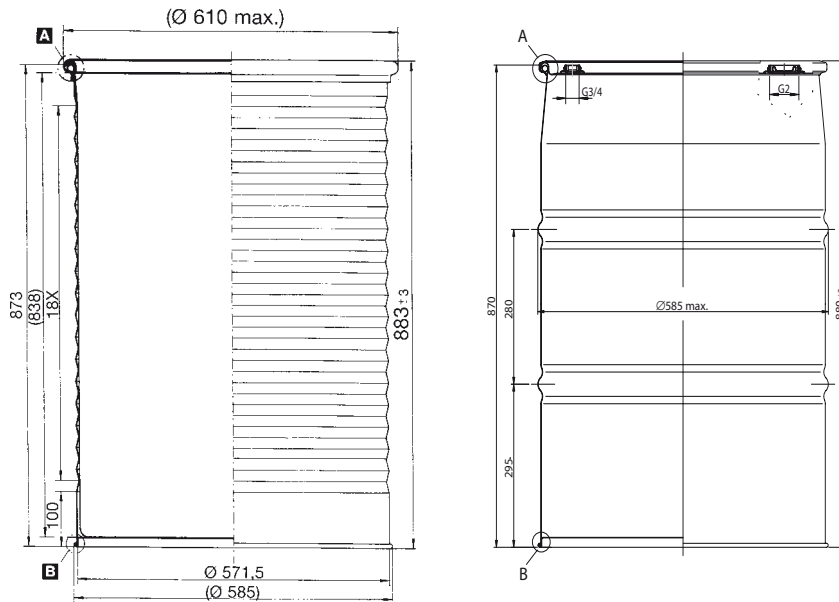

for containerisation

## Open head steel drums for liquid goods with/without PE-Inliner

Capacity Ltr.	Diameter mm	Thickness mm Bottom/Body/Top	UN Marking	Remarks
210	571,5 / 545	1,00 / 0,90 / 1,00	UN 1A2/Y1.4/120../CH/EGI-4204510	Closing ring 52 x 2,0 mm galvanized for containerisation
215	571,5	1,0 / 1,0 / 1,0	UN 1A2/Y120/Z1.8/120../CH2072	Closing ring 52 x 2/58 x 2
213	571,5	1,2 / 1,2 / 1,2	UN 1A2/Y120../CH2823	Closing ring 58 x 2 mm with/without PE-Inliner

## Open head steel drums for pasty and solid goods with/without PE-Inliner

Capacity Ltr.	Diameter mm	Thickness mm Bottom/Body/Bottom	UN Marking	Remarks
216,5	571,5	1,0 / 0,75 / 1,0	UN 1A2/Y300/S../CH2203	Closing ring 58 x 2 mm, no Inliner needed
216,5	571,5	1,0 / 0,75 / 1,0	UN 1A2/Y150/S../CH2203	Closing ring 40 x 1 mm, with PE-Inliner
216,5	571,5	1,0 / 0,75 / 1,0	UN 1A2/Y300/S../CH2702	Closing ring 58 x 2 mm, with PE-Inliner, and plastic-lid inside (option)
210	571,5 / 545	1,0 / 0,9 / 1,0	UN 1A2/Y320/S../CH4204438	Closing ring 42 x 1.5 ISO for containerisation
213	571,5	1,0 / 1,0 / 1,0	UN 1A2/Y300/S../CH/EGI-3642	Stainless Steel
213	571,5	1,0 / 1,0 / 1,0	UN 1A2/Y300/S../CH/EGI-4204310	Stainless Steel
216,5	571,5	1,0 / 1,0 / 1,0	UN 1A2/Y200/S../CH2072	Closing ring 40 x 1 mm, with PE-Inliner
216,5	571,5	1,2 / 1,0 / 1,2	UN 1A2/X200/S../CH2259	Closing ring 40 x 1 mm, with PE-Inliner
213	571,5	1,2 / 1,2 / 1,0	UN 1A2/Y200/S../CH/EGI-3548 UN 1A2/Y285/S../CH/EGI-3548	SPR 38 x 1 mm, with PE-Inliner SPR 40 x 1 mm
216,5	571,5	1,2 / 1,2 / 1,2	UN 1A2/Y200/S../CH/EGI-2055	Closing ring 40 x 1 mm, with PE-Inliner
210	571,5	1,5 / 1,5 / 1,5	UN 1A2/X280/S../CH/EGI-3960	

Other sizes and design upon request

For more information please contact us and ask for detailed technical documentation

Müller Ltd Packaging  
Tramstrasse 20  
CH-4142 Münchenstein 1

Phone: ++41(0)61/4161200  
Fax: ++41(0)61/4161222  
Internet: [www.muellerdrums.com](http://www.muellerdrums.com)  
E-mail: [info@muellerdrums.com](mailto:info@muellerdrums.com)

A Company of the Müller-Group  
[www.mueller-group.com](http://www.mueller-group.com)